

ELECTRO

BC – 4808 / 4810 / 4813 3 Stage Battery Charger User Manual

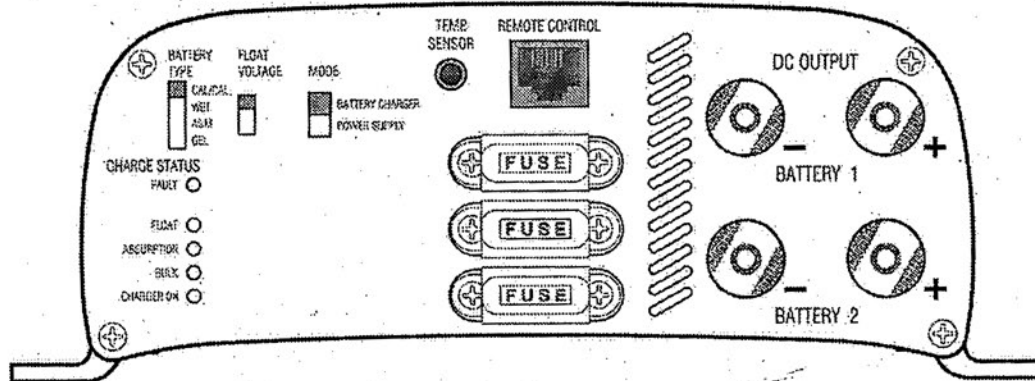

Keep this manual in a safe place for quick reference at all times.

This manual contains important safety and operation instructions for correct use of the battery charger. Read through the manual and pay special attention to the markings and labels of the charger, battery and equipment connected to the battery.

WARNING :

Failure to observe this warning may result in injury to persons, damage to equipment and improper functioning of the Charger.

- This range of Battery Chargers are designed for in-door use. Protect the charger from all liquids.
- Only charge properly sized batteries.
- Refer to battery manufacturer's recommendation for battery type setting and float voltage setting.
- Mount the charger to a solid base and in accordance with all local codes.
- Wear protective goggles and turn your face away when connecting or disconnecting the battery.
- Make sure all charger ventilation vents are unobstructed for efficient fan cooling.
- Do not charge non-rechargeable batteries.
- Charging wrong type or under-sized batteries may cause fire or explosion.
- Do not use the charger if it has been dropped or damaged.
- Do not remove charger casing as there is no user serviceable parts inside.
- Do not attempt to charge a frozen battery
- Do not attempt to charge a damaged battery.
- Do not place the charger on a battery.
- Do not smoke, use an open flame or create sparks near battery or charger during normal charging operation as batteries may give out explosive gases.
- Do not charge batteries in an enclosure due to possible explosion of entrapped explosive gases.
- Disconnect the mains supply before connecting or disconnecting the leads to the battery.
- If the charger does not operate properly or if it has been damaged unplug the AC and DC connections.
- If longer output charging cable is required, make sure the cable diameter is adequate for the cable length.

Introduction

Congratulations on purchasing our new 3-Stage Switch Mode Battery Charger. This battery charger is suitable for charging Wet, Sealed (VRLA), Calcium-Calcium, GEL and AGM batteries. It is a fully automatic battery charger that can be permanently left connected to the battery. These battery chargers have ability to charge two batteries simultaneously. The special selectable Power Supply Mode allows charging of the battery with an external load.

Intended Use:

All Automotive, Marine, Mobile Home, Electric Scooters, Golf Carts, Solar, Deep Cycle, UPS Standby, Industrial & Commercial Applications.

A. Control and Indicators

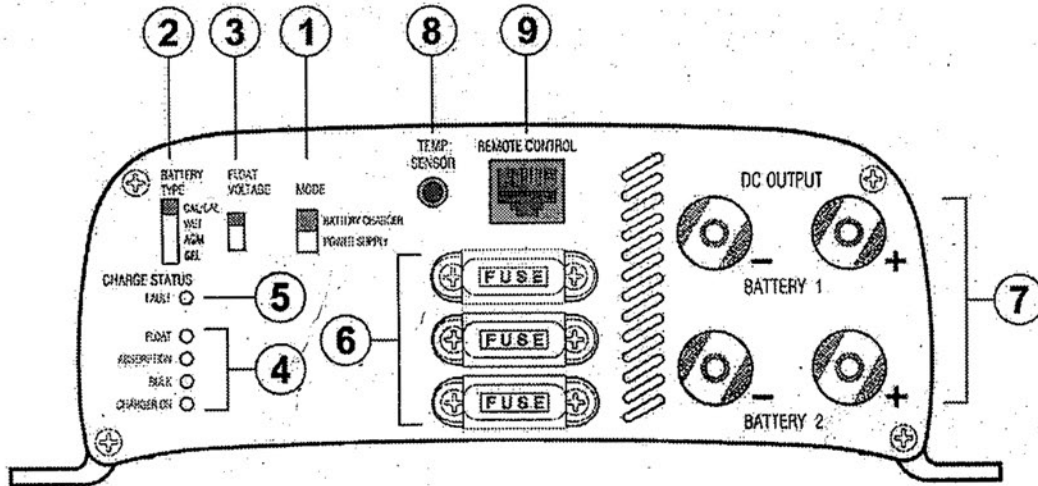

Fig.1

1. **Battery Charger / Power Supply Selection**
Slide the Switch to select 3-Stage Charging or Power Supply Mode (See Section G)
2. **Battery Type Selection**
Slide the Switch to select charging mode for GEL, AGM, Wet or Calcium-Calcium type battery.
3. **Float Voltage Selection**
Slide the Switch to select Float Charge Voltage (52.8 / 54.0V / 55.2V).
4. **Charge Status**

	LED Display
Charger ON	: Green - 3-Stage Charger Mode
	: Red - Power Supply Mode
BULK	: Red - Bulk charging with constant maximum current
ABSORPTION	: Orange - Absorption charging with preset constant maximum voltage.
FLOAT	: Green - Float charging with preset constant voltage
5. **FAULT LED (Red)**
Charger malfunction (See Trouble Shooting)
6. **Car Blade Fuse**
Reverse polarity protection fuse. Replace with same value.
7. **Output Cable Terminals**
Output charging cables terminals. Please observe polarity when connecting cables.
8. **Remote Temperature Sensor Socket**
Connection to Temperature Sensor ATS-5120.
Temperature Sensor will increase / decrease charge voltage at low / high battery temperatures.
9. **Remote Control Socket**
Connection to optional Remote Control Panel (ABD-4120).

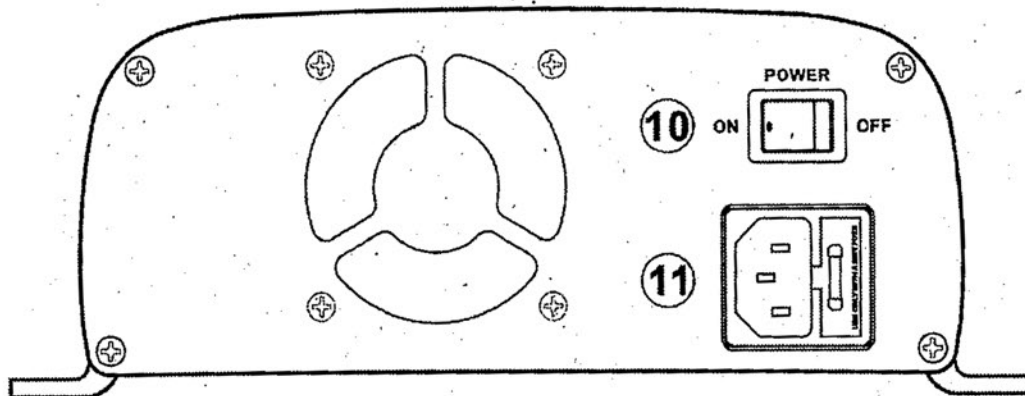

Fig.2

10. Power Switch

AC mains power ON/OFF switch.

11. AC Socket with inbuilt Fuse Holder

Connect to AC mains power with supplied AC power cord.

B. Battery Type Selection

- GEL : Gel sealed type maintenance free.
- AGM : AGM and VRLA sealed type maintenance free.
- WET : Automotive or Deep Cycle Lead Acid Batteries to which water can be added to, Calcium & Calcium-Calcium.
- CALCIUM : Calcium-Calcium type batteries are to be charged in this mode only when boost is required (62.2V). No load is to be connected to the battery during this charge mode. Charge through one cycle only then set back to WET charge setting.

B1. FLOAT VOLTAGE SELECTION

Follow the markings on the batteries for selecting Float Voltage setting. Choose 55.2V when in doubt or when operating in Power Supply Mode.

B2. Recommended Battery Capacity

The following minimum AH capacity is a generalized suggestion as some batteries can take higher charge currents. Check with battery manufacturers for charging details.

Charger Model	BC-4808 , 8A	BC-4810 , 10A	BC-4813 , 13A
Battery Capacity	30 AH - 80 AH	30 AH - 100 AH	40 AH - 150 AH

C. Battery Charger Installation and Connection

- Observe warnings and safety precautions before operating the charger.
- Check the battery condition, check the cell levels for wet type batteries and clean the battery terminals.
- Secure the battery charger in a well ventilated area making sure the mounting surface is flat. The air intake is at the bottom and the air outlet is at the back. Make sure both intake and outlet are not blocked.
- Never place charger on top of a battery.
- Plug in the AC mains and switch on the AC Power Switch. The Charger On LED and the Float LED should be on green indicating the Charger is ready for charging.
- Before connecting or disconnecting the charging cable, switch off the AC Power Switch and unplug the AC mains cord.
- First connect the Red cable to Positive (+) Terminal of the Charger and then to Battery Positive (+) Terminal.
- Second connect the Black cable to Negative (-) Terminal of the Charger then to Battery Negative (-) Terminal.
- Make sure all the connections are tight and secure as voltage drops can occur.
- Check again for correct charging settings.

D. Normal 3-Stage Charging Operation

3-stage battery charging operational graph.

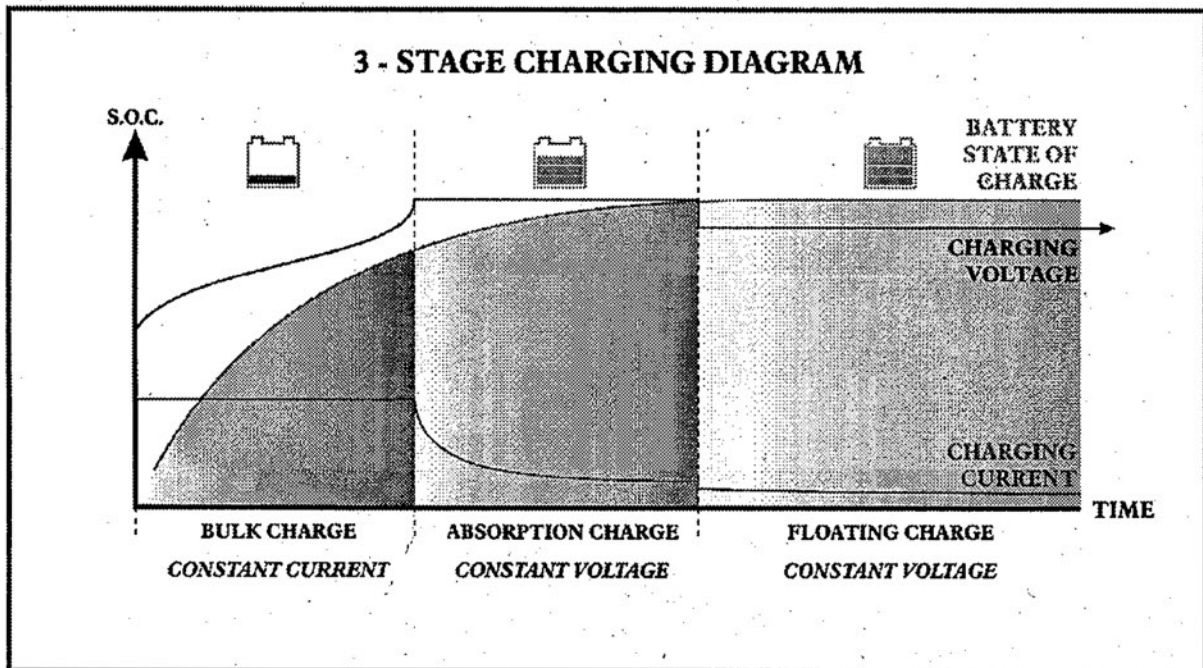

Fig.3

Stage 1. BULK. Constant current charging, Bulk LED is on.

The battery is charged at constant maximum current until it rises to the selected Absorption voltage level.

The charging voltage changes with the battery voltage.

If the initial battery voltage is less than 42.0V due to deep discharge, the bulk charge current is reduced to half of the maximum until battery voltage rises over 42.0V.

Stage 2. ABSORPTION. Constant voltage charging, Absorption LED is on.

Battery Type Selection : Gel : 56.4V / AGM: 57.2V / Wet : 57.6V / Calcium-Calcium : 62.2V

When the battery voltage rises to the selected Absorption Voltage Level, the charging switches to Constant Voltage Charging and the battery is over 85% full. The battery is kept at this high voltage while the current reduces gradually to set value at which the charger automatically switches to Float Stage.

Stage 3. FLOAT. Constant voltage charging, Float LED is on.

Float Voltage Selection : 52.8V / 54.0V / 55.2V

In this stage the battery is full and only takes in the amount of current necessary to maintain the battery capacity. The float voltage is preset by the user according to the type of battery used.

E. Manual Equalization Charging for Wet and Calcium-Calcium type batteries

Wet lead acid and Calcium-Calcium type batteries require periodic high voltage charging to balance the voltage of each cell, to reverse the high concentration of electrolyte at the bottom and clear up large sulfate crystals on the plates. You can use the Calcium-Calcium selection to perform manual equalization by carefully following battery manufacturer's instructions.

Make sure to manually switch off the charger at the end of equalization charging.

Take special precautions as batteries will emit explosive gases during equalization charging.

Do not have any loads connected to the batteries during equalization charging as higher voltage can cause damage to equipment.

F. Dual Battery Charging

This feature is for caravans and vehicles with two separate batteries.

The two batteries must be of same chemical make up and type to avoid over or under charging because only one setting of charging profile is possible for both.

Two batteries are charged simultaneously and the battery with the lower level will receive larger share of the current in the Bulk Charge Stage until it is brought up to the same voltage level as the other battery.

Both batteries will go to Absorption and Float Charge at the same time.

G. Power Supply Mode/2-Stage Battery Charger (see Fig.4)

In this mode the Charger can be used as Power Supply or 2-Stage Battery Charger.

This selected mode is intended to charge the batteries with external loads such as in caravans and motor homes.

The external load can draw power from the charger while the charger is charging the battery. The charger is not affected by the current draw being diverted by an external load as it will switch from Bulk to Float Mode.

2-Stage charger cannot completely charge the battery when the charger switches from Bulk to Float Mode and the battery will in most cases be about 80% charged. The battery will receive the remaining charge while in Float Mode over several days.

It is highly recommended to switch to 3-Stage Charger Mode periodically when the external load is disconnected.

The external load should not exceed 50% of the maximum current draw of the charger unless the battery is fully charged. If the Bulk LED is on most of the time then the load is too large:

G1. Power Supply Mode

The charger can also be used as a stand alone power supply without connection to a battery

It will provide a constant voltage according to the selected Float Voltage (52.8/54.0/55.2V) and rated DC current of the charger.

It is not recommended for high surge loads in stand alone applications as the initial high surge currents can trigger the overload protection circuit.

Fig.4 Power Supply / 2-Stage Charger Mode Application

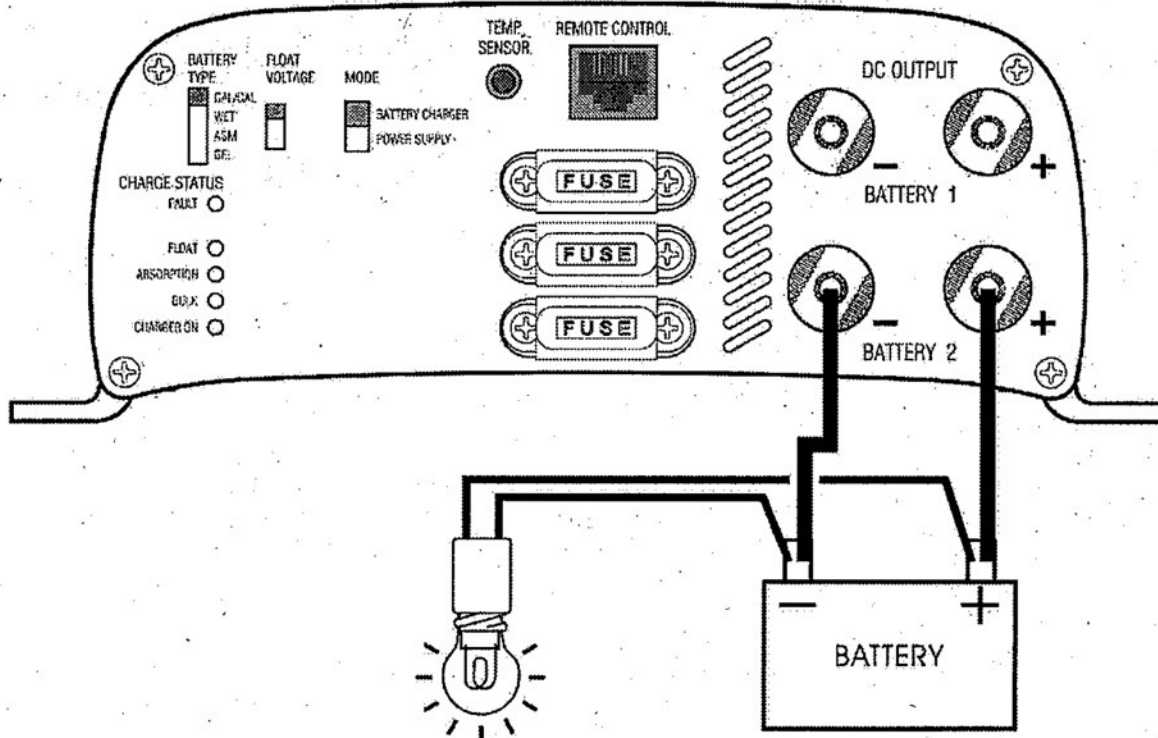

H. Temperature Sensor

Temperature Sensor ATS-5120 is to be used for optimal charging over wide range of ambient temperatures. Fix the temperature sensor on the battery that is not affected by external cooling or heating source. Plug in the temperature sensor and then switch on the charger to activate the temperature control function. Do not plug in the Temperature Sensor into the Charger during charging.



Fig.5

I. Cable Size Selection

Wire Size (AWG)	Area (mm ²)	Maximum one-way distance (Metres) for 2% Voltage loss (48V 8A)	Maximum one-way distance (Metres) for 2% Voltage loss (48V 10A)	Maximum one-way distance (Metres) for 2% Voltage loss (48V 13A)
10	5.26	17.0	14.0	10.0
8	8.37	27.0	22.0	17.0
6	13.3	44.0	35.0	27.0
4	21.2	70.0	55.0	43.0
2	33.6	110.0	88.0	67.0
1/0	53.5	177.0	141.0	109.0
2/0	67.4	220.0	176.0	135.0
4/0	107	323.0	258.0	200.0

Table: Selection of cable size and length versus current

J. Trouble Shooting

PROBLEM	INDICATIONS	POSSIBLE CAUSES	SUGGESTED SOLUTION
Charger does not work	Indicator lights not on	No AC power AC input socket fuse blown	Check AC connections. Replace AC fuse with correct value.
No DC output	Charger - On LED is off. Float and Fault LED's are on.	Output short circuit Over temperature protection triggered Severe over loading of the charger Reverse polarity connection	Check DC connections between charger and the battery Check that the air intake vent at the bottom of the charger is not blocked. Mount the charger in a ventilated area. Check if the battery AH capacity is within the recommended range Check for correct polarity, replace the blown car blade fuse (6)
Battery does not get full charge	All indicator LED's operate normally	Bad battery connection. Battery type select switch in wrong setting Battery capacity too large. Ambient temperature too low. Battery has a damaged cell or the battery is too old.	Check for loose contacts. Re-check battery type and change to correct battery selection Make sure charger rating matches battery capacity see table (B2) Move the battery to a room temperature location or use a temperature sensor Replace the battery
Long charging time, Float LED does not come on even after 20 hours of charging	Absorption light remains on all the time	Wrong battery type selection (eg. charging Gel battery with Calcium-Calcium OR Wet type selection) Total battery capacity is too high for dual charging Battery temperature too high Battery is defective A load is connected to the battery and the charger is not in Power Supply Mode.	Check the battery label and change battery type selection to correct setting. Check battery capacity or charge batteries separately Use a temperature sensor Replace the battery Change charger Selector Switch (1) to Power Supply Mode.
Bulk LED is on all the time	Bulk light remains on all the time when Charger is in Power Supply Mode, charger ON LED (4) is on red.	The connected load is too large, using most of the current from the charger.	Reduce the load to about 50% of the charger's rating current or take away the load and set the Charger to Battery Charger Mode to fully charge the battery before returning back to the Power Supply Mode.
	Bulk light remains on all the time when the Charger is in Battery Charger Mode	Wrong battery type selection Battery is excessively depleted and the soft charging is triggered Battery temperature is too high	Check the battery label and change the battery type selection to correct setting. Recharge the battery after a day, if bulk light remains after several hours, the battery is most likely damaged and cannot accept charge. Replace the battery. Use a temperature sensor

K. Specifications

Model	BC - 4808	BC - 4810	BC - 4813	
Output	Absorption Charge Voltage Selections	GEL : 56.4V ; AGM: 57.2V ; WET : 57.6V ; CALCIUM-CALCIUM : 62.2V		
	Absorption Charge Timer	4hrs		
	Float Charge Voltage Selections	52.8V, 54.0V, 55.2V		
	Battery Charger / Power Supply Selections	Yes	Yes	Yes
	Maximum Output Charging Current (Continuous)	8A	10A	13A
	Recommended Battery Capacity Range	30 - 80AH	30 - 100AH	40 - 150AH
	Soft Start Bulk Charge			
	Battery Voltage to Trigger (cut-in) Soft Start Bulk Charge Mode	<42.0V		
	Soft Start Bulk Charge Current (Current Limit)	4A	5A	6.5A
	Line Regulation (90-260V) for Charging Current	<0.5%		
	Ripple and Noise (Peak to Peak)	<300mV	<300mV	<300mV
	Efficiency at Maximum Power (100V/230V)	>86/90%	>86/90%	>86/90%
	Dual Bank Charging (Battery must be of same type)	Yes	Yes	Yes
Input	AC Voltage Range	100 - 240V 50Hz~		
	AC Current at Full Load (100V/230V)	5.6/2.5A	7.3/3.1A	9.5/4.1A
Protection	Overload	90-110% Rated Output Current or 50% Rated Output Current (Soft Charge) Protection Type : Constant Current Limiting, recovers Automatically after Fault Condition is Removed.		
	Short Circuit	Recovers Automatically After Fault Condition is Removed		
	Reverse Polarity	Car Blade Fuse		
	Over Temperature	Protection Type: Shut Down		
	OVP Output Over Voltage	Yes		
Cooling	Cooling Method	Thermostatic, Variable Speed Fan		
Indicators	3-Stage Battery Charger / Power Supply Mode	Yes		
	Charge Phase Bulk / Absorption / Float	Yes		
	Fault Mode	Yes		
	AC Power	Yes		
Fuses	AC Fuses at IEC AC Power Socket	T6.3A	T8A	T10A
	DC Car Blade Fuse at Front Panel	15Ax1	15Ax1	20Ax1
Accessories	Remote Temperature Sensor, Cable & Spare Fuses	Yes		
	Remote Control Panel	Optional		
Approvals	Safety : Q061375	Yes		
	EMC: N2926	Yes		
Others	Dimensions and Weight	220x80x200mm ; 2.4kg	220x80x261mm ; 3.0kg	220x80x261mm ; 3.2kg
Remarks	All values are based on the standard ambient temperature 25°C and pressure 0.1Mpa.			