

## BATTERY PROTECTOR

### BP – 400 / 500 / 600

#### INSTALLATION:

1. Connect the White cable to the positive terminal of your appliance .
2. Connect the negative terminal of your appliance to the negative terminal of battery or metal frame of your vehicle.
3. Connect the black cable to the negative terminal of battery or metal frame of your vehicle.
4. Connect the Red cable to the positive terminal of battery.
5. Connect the blue cable to the remote ON/OFF switch, one side of the remote switch must be grounded.

#### Battery Protector Wiring diagram

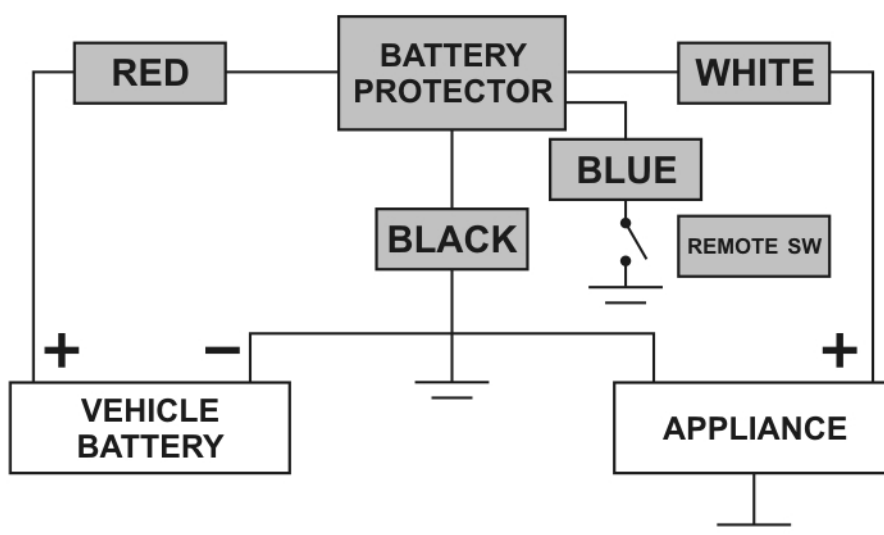

#### NOTE :

1. Battery Protector will cut the supply to your appliance when the battery voltage falls below the selected voltage.
2. Main or remote switch will operate the battery protector. To operate the remote switch, main switch must be switched to OFF position.